

HC Series

Standard Centrifugal Pumps- Bearing Frame

PAGE: CP-755

DATE: June 5, 2006

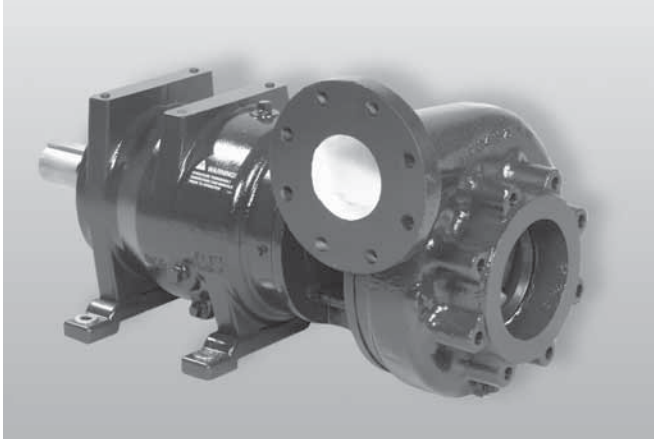

FPS

HCseries

Features:

- 1-1/2" - 10" discharge sizes
- Capacities to 7000 GPM, 480' TDH
- Horsepower: Up to 200 HP
- Standard ductile iron construction with bronze wear ring and sleeve
- Replaceable wear rings
- Superior NPSH characteristics
- 150# rated flat faced flanges
- Heavy wall construction
- Grade 5 capscrews
- HC75 & HC10 Series- Enclosed impellers, internally hydraulically balanced
- Double volute on HC10x10-14, for balanced radial forces, HC14 Series- External balance line standard
- Standard with graphite packing or single mechanical seal

Model Number Explanation

Example: HC31575-BFP

HC = Horizontal Centrifugal
3 = Suction Size
15 = Discharge Size
75 = Nominal Impeller Dia.
BF = Bearing Frame
P = Shaft Sealing:
P=Packing
M=Mechanical Seal