

TYCI Series Self Priming Sprinkler Pumps - Cast Iron

PAGE: CP-205
DATE: June 5, 2006



Features:

- Heavy duty cast iron case with engineered high efficiency, quiet run design
- High performance, thermoplastic hydraulics, including floating eye seal and stainless steel impeller wear ring
- 1-1/2" FNPT threaded suction and discharge ports
- Self-priming with large 1" priming port
- Built in drain plug to facilitate servicing/winterizing
- Handles water temperatures up to 120°F and working pressure up to 75 PSI
- All models have 2 compartment motors
- Easy motor toggle switch changes from 230V to 115V without rewiring (Not available on 2HP)

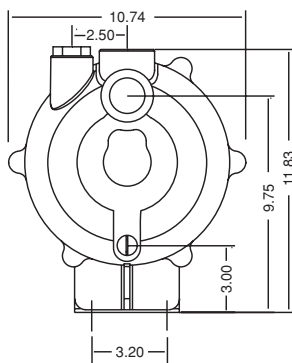
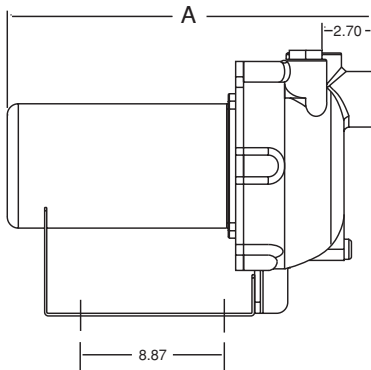

Dimensions (In inches)

HP	Frame	A
3/4	48	18-1/4"
1	48	18-1/2"
1-1/2	48	18-3/8"
2	56	19-7/8"

Ordering Information

SELF-PRIMING LAWN SPRINKLER PUMPS				
Model	HP	Voltage	PUMP UNIT	
			Order No.	Wt.
7FPTYCI	3/4	115/230	93373007	51
10FPTYCI	1	115/230	93373010	66
15FPTYCI	1-1/2	115/230	93373015	82
20FPTYCI	2	230	93373020	99

Note: Dimensions will vary according to motor manufacturer.

TYCI Series Performance

Self Priming Sprinkler Pumps - Cast Iron

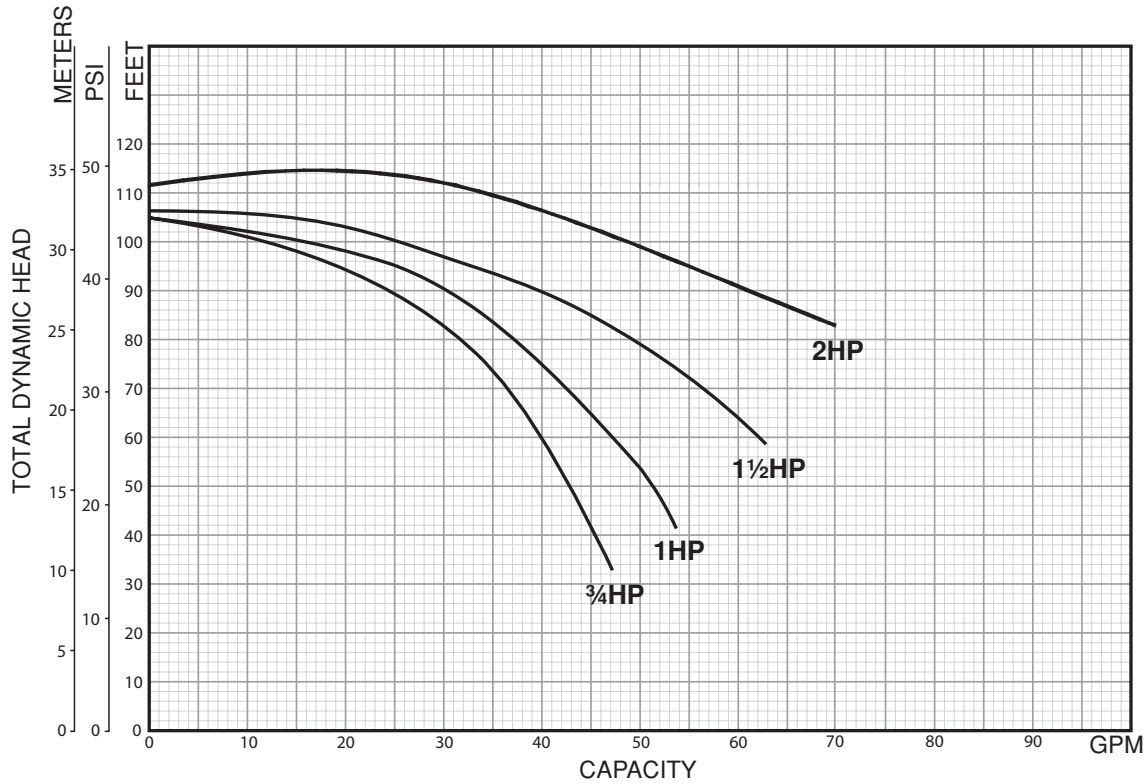

HP	Total Suction Lift in feet	Discharge PSI					Shut off Pressure (PSI)
		20	25	30	35	40	
		Capacity in GPM					
3/4	5	43	39	35	28	16	42
	10	41	37	32	23	-	40
	15	39	35	29	18	-	38
	20	38	33	25	-	-	35
1	5	50	45	40	33	21	43
	10	49	44	37	29	7	41
	15	46	41	35	24	-	39
	20	44	39	31	12	-	36
1-1/2	5	65	60	54	44	30	44
	10	64	57	50	38	21	42
	15	61	54	46	31	7	40
	20	58	50	41	23	-	37
2	5	79	76	72	65	52	46
	10	78	74	69	59	45	44
	15	76	72	67	54	38	42
	20	74	70	63	47	20	39



Franklin Electric

400 East Spring Street, Bluffton, IN 46714

Tel: 260.824.2900 Fax: 260.824.2909

www.franklinpumps.com